

XTENDEX® Series

ST-1FO3GSDI-(12V)LC

SD/HD/3G-SDI Extender via Fiber Optic Cable

Installation and Operation Manual



TRADEMARK

XTENDEX and the NTI logo are registered trademarks of Network Technologies Inc in the U.S. and other countries. All other brand names and trademarks or registered trademarks are the property of their respective owners.

COPYRIGHT

Copyright © 2022 by Network Technologies Inc. All rights reserved. No part of this publication may be reproduced, stored in a retrieval system, or transmitted, in any form or by any means, electronic, mechanical, photocopying, recording, or otherwise, without the prior written consent of Network Technologies Inc, 1275 Danner Drive, Aurora, Ohio 44202.

CHANGES

The material in this guide is for information only and is subject to change without notice. Network Technologies Inc reserves the right to make changes in the product design without reservation and without notification to its users.

TABLE OF CONTENTS

Introduction.....	1
Materials.....	1
Connectors and LEDs.....	2
Preparation for Installation.....	3
Connections.....	4
Technical Specifications.....	5
Troubleshooting.....	5
Warranty Information.....	6

INTRODUCTION

The XTENDEX® SD/HD/3G-SDI Extender via Fiber Optic Cable locates up to two displays from a SD/HD/3G-SDI video source up to 12.4 miles (20 kilometers) away using a single singlemode LC fiber optic strand and 1,640 feet (500 meters) using multimode fiber optic cable (OM2 and above). Each extender consists of a transmitter that connects to a SD/HD/3G-SDI video source and a local loop out, and a receiver that connects to up to two SD/HD/3G-SDI displays.

Features:

- Signal transmission via one singlemode or multimode LC fiber optic cable.
 - Using singlemode 9-micron cable, extend to 12.4 miles (20 kilometers).
 - Using multimode 50-micron cable, extend to 1,640 feet (500 meters).
- Supports HDTV resolutions to 1080p @60Hz.
- Simultaneously transmits to two SD/HD/3G-SDI displays at the receiver.
- Supports a local display via loop out SDI connector.
- Supports unidirectional RS485 from the receiver to the transmitter.
- Plug-and-play functionality – no software needed.
- Low RFI/EMI for sensitive applications.
- Cables can be installed in conduit prior to extender installation.
- Integrated mounting brackets for easy surface/wall mounting.
- Available power options: 5VDC or 12VDC

MATERIALS

Materials supplied with this kit:

- Local and Remote Unit
- 2 x 100-240VAC, 50 or 60Hz-5VDC/3A AC Adapter **(For ST-1FO3GSDI-LC)**
 - or
- 2 x 100-240VAC, 50 or 60Hz-12VDC/1A AC Adapter **(For ST-1FO3GSDI-12VLC)**
- 2- Country-specific power cords
- URL Slip with path to this manual

Note: *ST-1FO3GSDI-LC12VNP is does not include any power supply*

Materials Not supplied but **REQUIRED:**

- Interface cables (RG6) between the video source/display and the transmitter/receiver are required for proper operation.
 - 3G-SDI: up to 328 ft (100 m)
 - HD-SDI: up to 656 ft (200 m)
 - SD-SDI: up to 984 ft (300 m)
- Use a simplex LC singlemode 9/125-micron fiber optic cable to extend the receiver from the transmitter up to 12.4 miles (20 kilometers).
- Use a simplex LC multimode 50/125-micron (OM2/OM3/OM4) fiber optic cable to extend the receiver from the transmitter up to 1640 feet (500 meters).

CONNECTORS AND LEDS

ST-1FO3GSDI-LC (Local Unit)

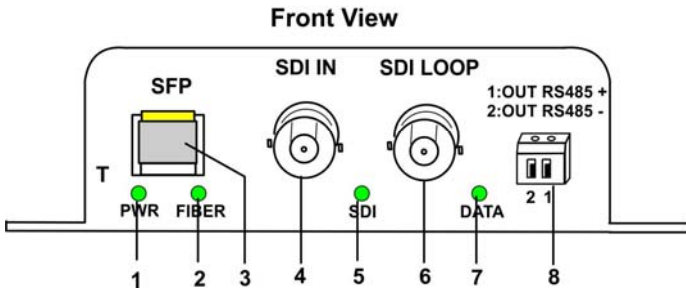

Rear View

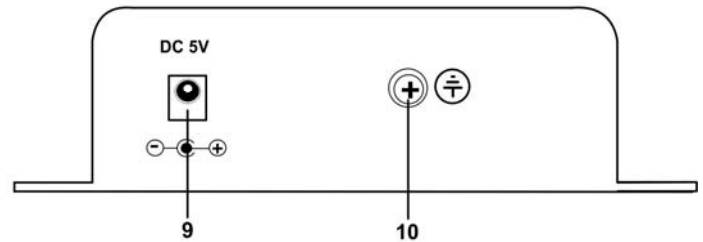

ST-1FO3GSDI-LC (Remote Unit)

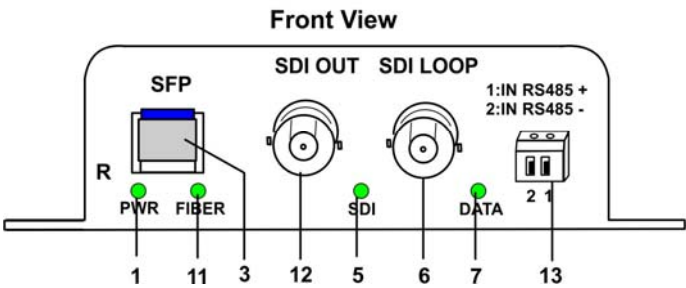

Rear View

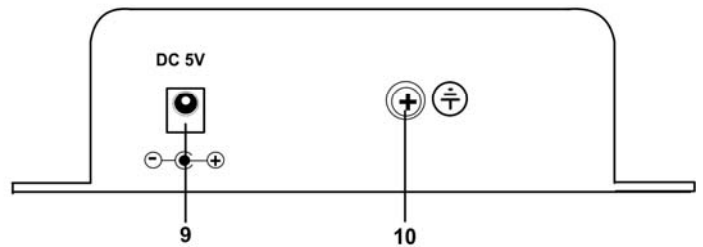

#	LABEL	CONNECTOR	DESCRIPTION
1	PWR	Green LED	Status LED to indicate power ON at the Local/Remote
2	FIBER	Green LED	Status LED to indicate a fiber connection with the Remote Unit
3	SFP	SFP Module	For connecting fiber cable between the Local and Remote units
4	SDI IN	BNC Female	For connecting BNC cable from SDI video source
5	SDI	Green LED	Status LED to indicate SDI transfer between Local and Remote
6	SDI LOOP	BNC Female	For connecting SDI cable from display device
7	DATA	Green LED	Status LED blinks to indicate there is an active RS485 signal present.
8	2 & 1	2-Terminal Block	For connecting RS485 device to be controlled
9	DC 5V	Power Jack	For connecting DC power supply ST-1FO3GSDI-12VLC power jack will be labeled "DC 12V" instead.
10	GND Symbol	Ground Screw	For connecting earth ground wire
11	FIBER	Green LED	Status LED to indicate an SDI video signal from the Local Unit
12	SDI OUT	BNC Female	For connecting BNC cable from SDI display device
13	2 & 1	2-Terminal Block	For connecting RS485 control device

LED Behavior

Local PWR - Illuminates when the Local Unit has power ON.

Remote PWR - Illuminates when the Remote Unit has power ON.

Local and Remote FIBER - If there is no source connected to "SDI IN", but there is a fiber between the Local and Remote Unit, the "FIBER" LED on the Local will illuminate, and the "FIBER" LED on the Remote will not.
If a source is connected to "SDI IN", the "PWR", "FIBER" and "SDI" LEDs on the Local and Remote Unit will illuminate.

Local and Remote DATA - When an active RS485 signal is present, this LED will blink.

PREPARATION FOR INSTALLATION

- Locations should be chosen for the monitor that also has space to connect the Remote unit within the distance provided by the cables.
- All cables should be installed in such a way that they do not cause stress on their connections to the equipment. Extended lengths of cable hanging from a connection may interfere with the quality of that connection. Secure cables as needed to minimize this.
- The RG6 cables must be routed such that the cables are away from any sources of magnetic fields or electrical interference that might reduce the quality of the video signal (i.e. AC motors, welding equipment, etc.).
- Properly shut down and disconnect the power from the video source and monitor(s) to be separated. If other equipment is involved whose connections are being interrupted, be sure to refer to the instruction manuals for that equipment for proper disconnection and reconnection procedures before proceeding.

CONNECTIONS

1. Connect camera or other output device to "SDI IN" BNC connector on the Local Unit.
2. If the output device has RS485 control connections, connect the "-" wire to terminal "2" and the "+" wire to terminal "1" of the Local Unit.
3. Optionally connect an SDI display to the "SDI LOOP" BNC connector on the Local Unit.
4. Connect type LC simplex fiber optic cable between the Local Unit and Remote Unit.
5. Power ON the Output device and SDI display (if installed).
6. Connect a DC adapter to the Local Unit and power the Local Unit ON.
7. Connect SDI display(s) to "SDI OUT" and "SDI LOOP" BNC connectors.
8. If the output device has RS485 control connections, connect the controller "-" wire to terminal "2" and the "+" wire to terminal "1" of the Remote Unit from the RS485 controller.
9. Power ON the SDI display(s).
10. Power ON the Remote Unit.

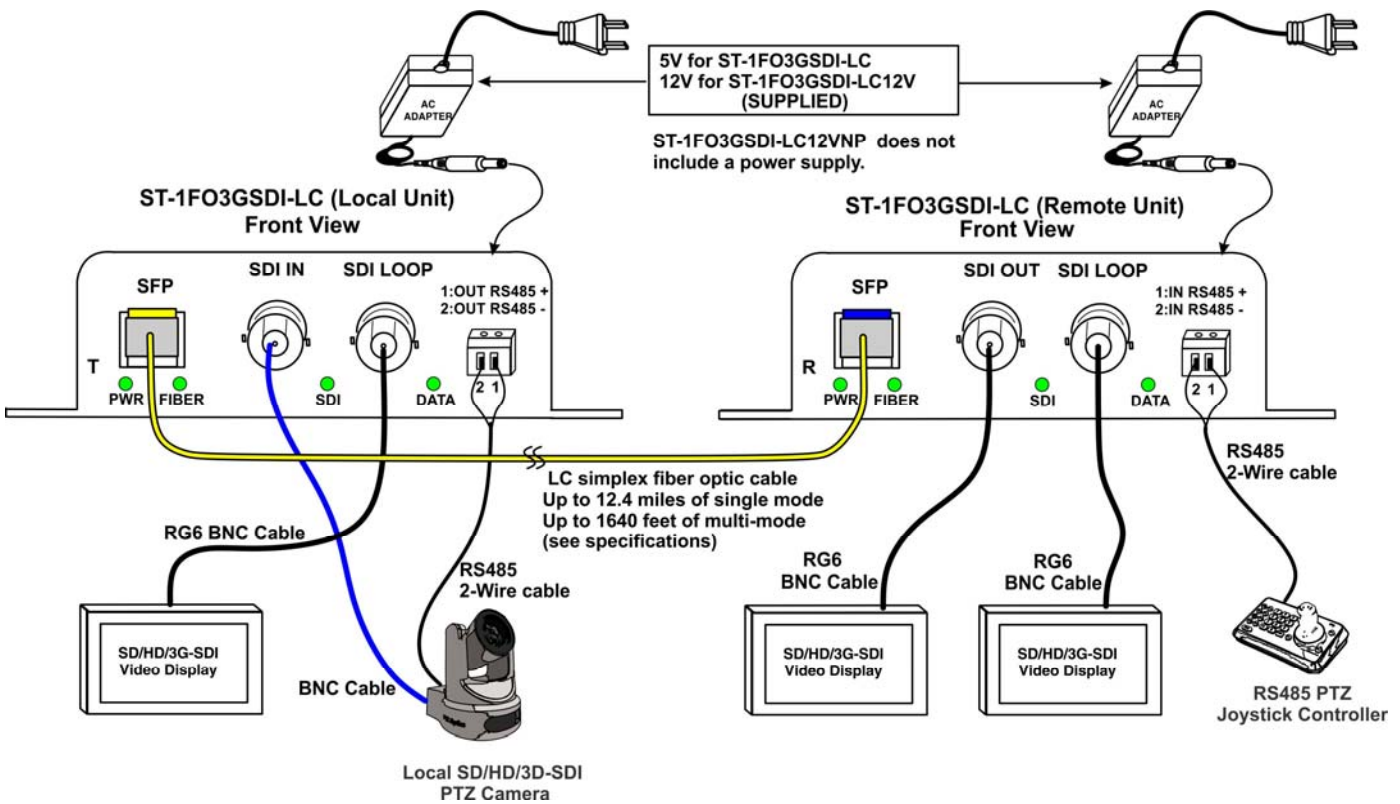

Cables to Use:

- Interface cables (RG6) between the video source/display and the transmitter/receiver are required for proper operation.
 - 3G-SDI: up to 328 ft (100 m)
 - HD-SDI: up to 656 ft (200 m)
 - SD-SDI: up to 984 ft (300 m)
- Use a simplex LC singlemode 9/125-micron fiber optic cable to extend the receiver from the transmitter up to 12.4 miles (20 kilometers).
- Use a simplex LC multimode 50/125-micron (OM2/OM3/OM4) fiber optic cable to extend the receiver from the transmitter up to 1640 feet (500 meters).
- **Cables are not included.**

TECHNICAL SPECIFICATIONS

Items	Specification
Local Unit	
Devices supported	SD/HD/3G-SDI Video Source SD/HD/3G-SDI Video Display
Connectors	2- Female 75 ohm BNC connector 1- Female LC fiber connector 1- 2-pin terminal block (RS485)
Remote Unit	
Connectors	2- Female 75 ohm BNC connector 1- Female LC fiber connector 1- 2-pin terminal block (RS485)
General	
Operating Temperature	-4 to 131°F (-20 to 55°C).
Storage Temperature	-40 to 185°F (-40 to 85°C).
Operating and Storage Humidity	0 to 95% RH (no condensation)
Video Resolutions Supported	Supports HDTV resolutions to 1080p @60Hz. Protocols supported: SMPTE 292M, SMPTE 424M, SMPTE 425M Supports NTSC and PAL video.
RS485 Supported	Supports unidirectional RS485 from the receiver to the transmitter. Baud rate: 1200, 9600, 115200
Power Supply	ST-1FO3GSDI-LC Local and remote unit: Input: 100 to 240 VAC at 50 or 60Hz via AC adapter (included). Output: 5VDC, 3A ST-1FO3GSDI-LC12V Local and remote unit: Input: 100 to 240 VAC at 50 or 60Hz via AC adapter (included). Output: 12VDC, 1A
Power Consumption	ST-1FO3GSDI-LC Local and remote unit: 2.5W ST-1FO3GSDI-LC12V Local unit: 2.52W Remote unit: 2.16W
Dimensions (WxDxH)	4.81x4.11x1.13 in (122x104x29 mm)
Maximum Extension Distance	12.4 miles (20 km) over singlemode 9/125-micron LC simplex fiber optic cable. 1640 feet (500 meters) over multimode 50/125-micron (OM2/OM3/OM4) LC simplex fiber optic cable.
Weight	Local: 221g (.488lb) Remote: 215g (.474lb)
Regulatory Approvals	CE, FCC, RoHS

TROUBLESHOOTING

Problem	Solution
Local Unit	
Power LED not working	Check power connections thoroughly.
No Video Signal	<p>Check the SDI LED on the Remote Unit.</p> <p>If LED illuminates, it means there is a video signal on this channel. Check the connections of the video display equipment.</p> <p>If LED is dark, it means there is no video signal to the Remote Unit. Check if the SDI LED on the Local Unit is illuminated or not. Cycle power on the Remote and Local Units to sync the signals up.</p>
Display has "snow" interference	<p>This is normally caused by attenuation of the fiber cable or a long cable between the video source and the Local Unit. Always use the highest quality cables available.</p> <ol style="list-style-type: none"> 1. Make sure the fiber cable does not have any bends in it that exceed the cables specification 2. Check the cleanliness of the fiber port and fiber cable ends. Clean using cotton swab and alcohol. 3. Use 75 ohm impedance RG6 cables between the displays and the Local/Remote units and to the video source. Be sure to route away from other sources of electromagnetic interference.

WARRANTY INFORMATION

The warranty period on this product (parts and labor) is two (2) years from the date of purchase. Please contact Network Technologies Inc at **(800) 742-8324** (800-RGB-TECH) or **(330) 562-7070** or visit our website at <http://www.networktechinc.com> for information regarding repairs and/or returns. A return authorization number is required for all repairs/returns.

MAN419 Rev. 3/8/22